

Continental

Designer-line
FREEZERS

Refrigerator

ROLL-IN & ROLL-THRU FREEZERS

Standard Features

Utilizing Environmentally Safe, CFC-free R-404A Refrigerant



DL1FI-SS

DL2FI-SS

DL3FI-SS

- Modern, State-Of-The-Art Styling
- Performance Rated, "Plug" Refrigeration System Utilizing Environmentally Safe R-404A Refrigerant
- 3" High Density, Non-CFC Polyurethane Foam Insulation
- Chrome-Plated Flow Line Handles
- Cam-Action Lift-Off Hinges
- Cylinder Lock in Each Door
- Automatic Hot Gas Condensate Evaporator
- 27³/₈" Wide, 66¹/₂" High Door Openings
- External Digital Thermometer
- Automatic Electric Defrost
- Removable Stainless Steel Rack Guides
- Magnetic Snap-In Door Gaskets
- Unique Air Flow Distribution Ducts Keep Pan
- Product at Uniformly Constant Temperatures

Standard (S/S Front, Aluminum Ends & Interior)
Suffix SA (S/S Exterior, Aluminum Interior)
Suffix SS (S/S Exterior & Interior)

Optional Features & Accessories

- Roll-Thru
- Glass Door
- Remote
- Consult Factory

REFRIGERATION SYSTEM

A "performance rated", air-cooled hermetically sealed, capillary type refrigeration system is installed on the top of each freezer. Plasticized fin coil and air circulating fans are contained within a concealed "plug" type insulated housing, readily accessible on the top of the cabinet and separate from the food zone to increase food storage capacity. The entire "plug" system is fully charged with environmentally safe R-404A refrigerant and mounted on a sturdy steel, rail type base, which can be easily removed if refrigerator conversion is desired. Freezers are designed to maintain 0 degrees Fahrenheit (-18 degrees Centigrade) while operating with an unrestricted air supply in a maximum ambient temperature of 100 degrees Fahrenheit. Automatic electric defrost timer initiates defrost cycles at predetermined intervals. All condensate water is evaporated by an automatic, non-electric, corrosion-resistant condensate evaporator. A strict quality-assurance team inspects all materials and components to the most exacting standards. All models are factory performance-tested for a minimum of 16 hours prior to crating.

CABINET CONSTRUCTION

All materials are of top quality, and are assembled under rigid supervision conforming to strict quality assurance requirements. The cabinet front, doors, and interior bottoms, are constructed of heavy gauge polished stainless steel for durability. All cabinet joints and seams are sealed vapor tight. Case is of all metal welded construction and is internally supported and braced for rigid unit construction. Cabinet design eliminates overlapping panels with raw edges. Cabinet body and doors are insulated with non-CFC, foamed in place polyurethane foam with an average thickness of 3 inches to ensure increased energy efficiency. Full-length louvered air grille located above the doors allows equal air circulation to the condensing unit. Easily removable, low-wattage, anti-sweat door heaters concealed by a non-metallic, non-conductive, high-impact thermal breaker strip eliminate condensate build up on the cabinet front. Automatic interior lighting is controlled by door openings. Cabinets are equipped with an easily removable stainless steel ramp and interior rack guides.

DOOR CONSTRUCTION

Doors shells are constructed of a heavy gauge stainless steel and are internally braced and urethane foam insulated for rigidity. Door corners are of welded construction and polished. Replaceable snap-in door gaskets are self-adjusting, heavy-duty, magnetic type. Doors handles and hinges are chrome-plated and non-corrosive. Doors are provided with built-in cylinder locks, which are keyed alike. Hinges are cam action, lift-off type featuring a positive safety stop at 120 degree.



c





SPECIFICATIONS

	DL1FI-SS		DL2FI-SS		DL3FI-SS	
DIMENSIONAL DATA	ROLL-IN	ROLL-THRU	ROLL-IN	ROLL-THRU	ROLL-IN	ROLL-THRU
Net Capacity (cu. ft.)	32	32	64	64	96	96
Width, Overall (in.)	35 1/2	35 1/4	68 1/2	68 1/2	101 3/4	101 3/4
Depth, Overall, Incl. Hlds.(in.)	35 1/2	39	35 1/2	39	35 1/2	39
Depth (Less Door(s))(in.)	32	32	32	32	32	32
Depth(Door(s) Open 90°)(in.)	65	98	65	98	65	98
Clear Door Width(in.)	27 3/8	27 3/8	27 3/8	27 3/8	27 3/8	27 3/8
Clear Full-Door Height (in.)	66 1/2	66 1/2	66 1/2	66 1/2	66 1/2	66 1/2
Height, Overall (in.)	86	86	86	86	88	88
No. of Full Door(s)	1	2	2	4	3	6
Rack Capacity*	1	1	2	2	3	3
REFRIGERATION DATA						
Condensing Unit Size (H.P.)	3/4	3/4	1	1	2	2
Capacity (BTU/Hr)**	3530	3530	4150	4150	9250	9250
Refrigerant	R-404A	R-404A	R-404A	R-404A	R-404A	R-404A
ELECTRICAL DATA						
Cabinet Specifications	115/208-230/60/1	115/208-230/60/1	115/208-230/60/1	115/208-230/60/1	115/208-230/60/1	115/208-230/60/1
Feed Wires (Incl. Ground)	4	4	4	4	4	4
Condensing Unit Specs.	208-230/60/1	208-230/60/1	208-230/60/1	208-230/60/1	208-230/60/1	208-230/60/1
Total Amperes	11.1	11.6	13.5	14.5	20.7	22.2
Cabinet Amperes	1.9	2.4	3.1	4.1	4.3	5.8
Defrost Amperes	9.6	9.6	9.6	9.6	19.2	19.2
Power Supply Cord	no	no	no	no	no	no
SHIPPING DATA						
Height-crated (in.)	90	90	90	90	90	90
Width-crated (in.)	43	43	77	77	109	109
Depth-crated (in.)	42	42	42	42	42	42
Volume-crated (cu. ft.)	94	94	168	168	238	238
Weight Std-crated (lbs.)	475	550	780	900	960	1100
Weight SS-crated (lbs.)	580	660	825	950	1050	1210
Weight Std - uncrated (lbs.)	380	435	625	720	760	875
Weight SS - uncrated (lbs.)	460	530	660	760	840	960

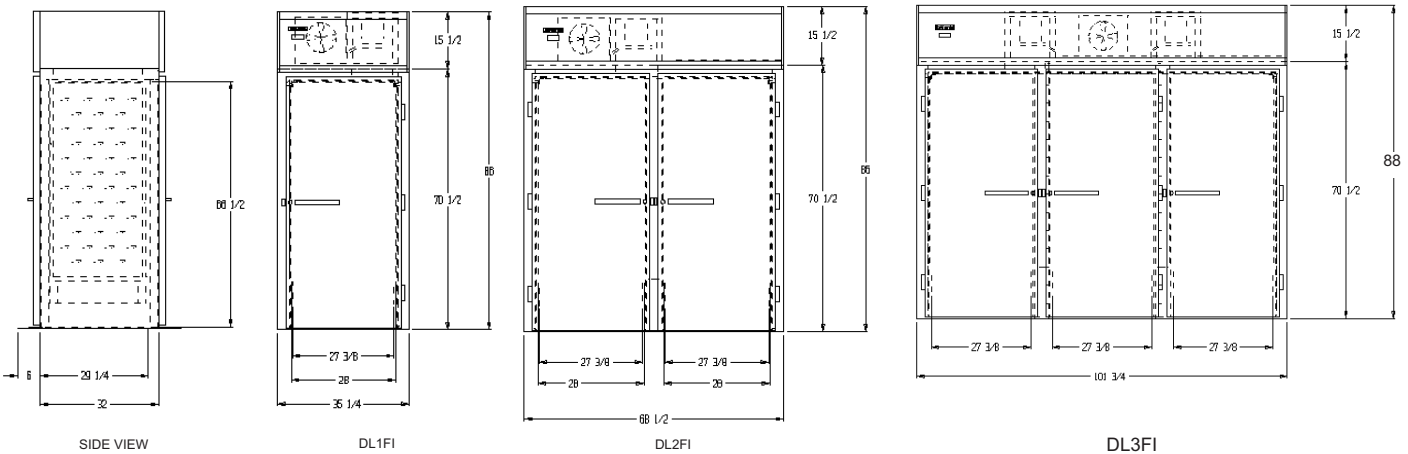

A Division of National Refrigeration & A/C Products, Inc.
 539 Dunksferry Road Bensalem, PA 19020
 (800) 523-7138 Fax: (215) 244-9579
 www.continentalrefrigerator.com